

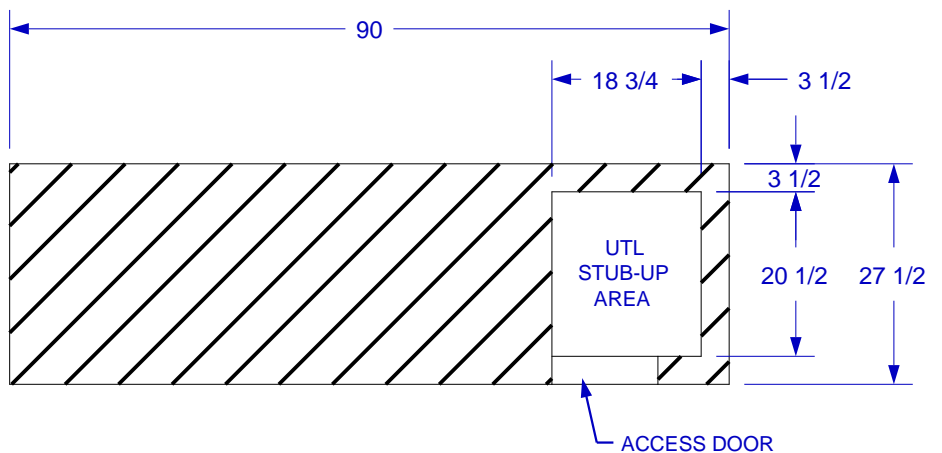

# REVERSED DECA Q ISLAND WITH BRAHMA SPEC SHEET

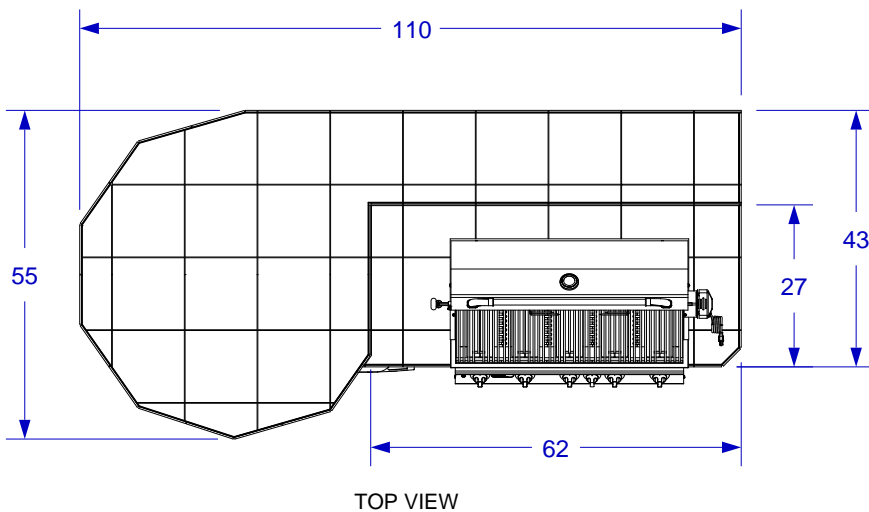
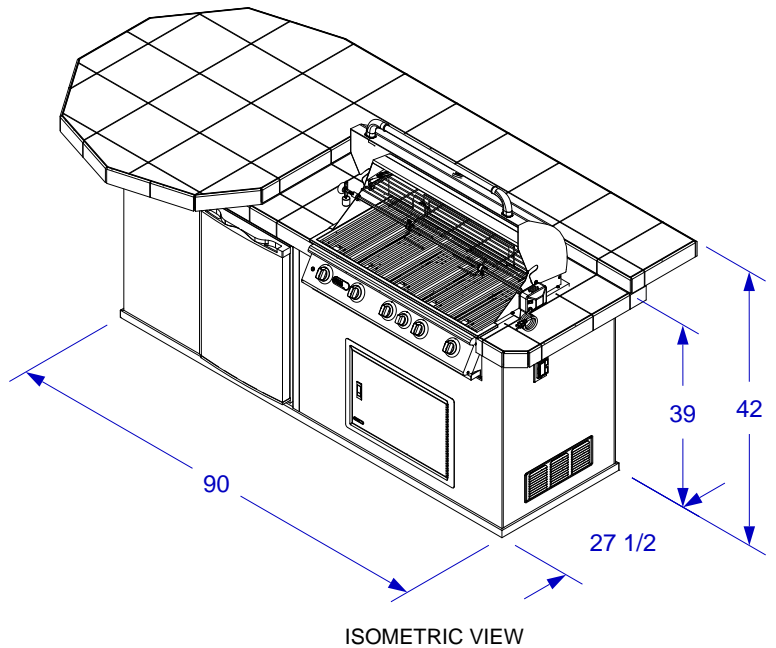

- NOTES:**
1. FOR ROCK FINISHES, ADD 1 1/2" ON ALL BASE SIDES.
  2. 6" MAX HEIGHT ON ALL STUB-UPS.
  3. SHOWN WITH OPTIONAL 5-BURNER BRAHMA GRILL.
  4. SCALE: 3/8" = 1'-0"

STUB-UP DIAGRAM  
SCALE 1/2" = 1' 0"  
(SEE NOTE #2)