

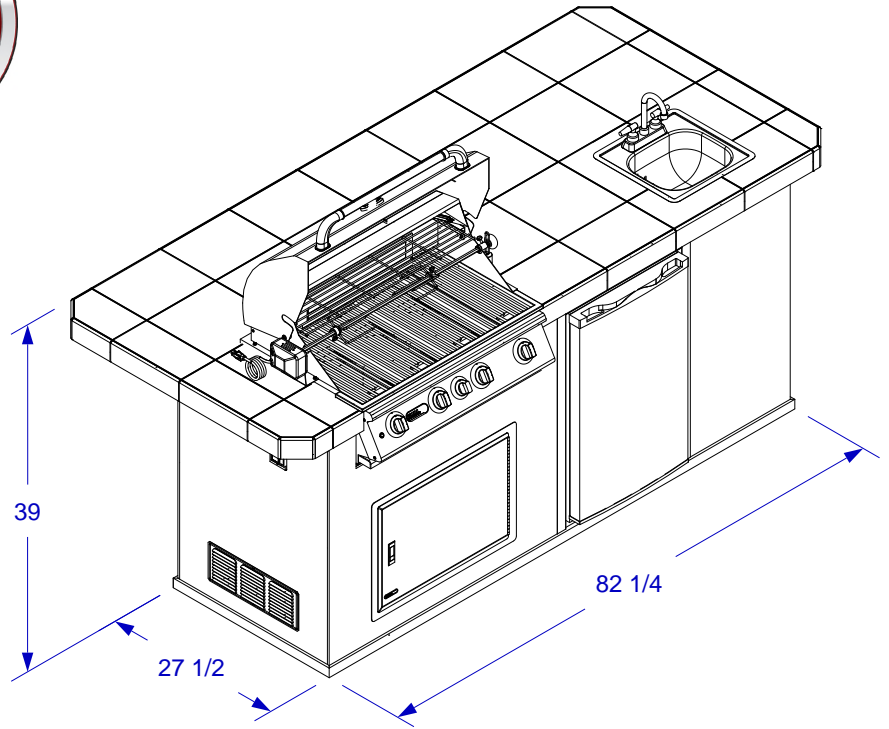

**OUTDOOR KITCHEN**  
**ISLAND W/ 43" TOP**  
**SPEC SHEET**

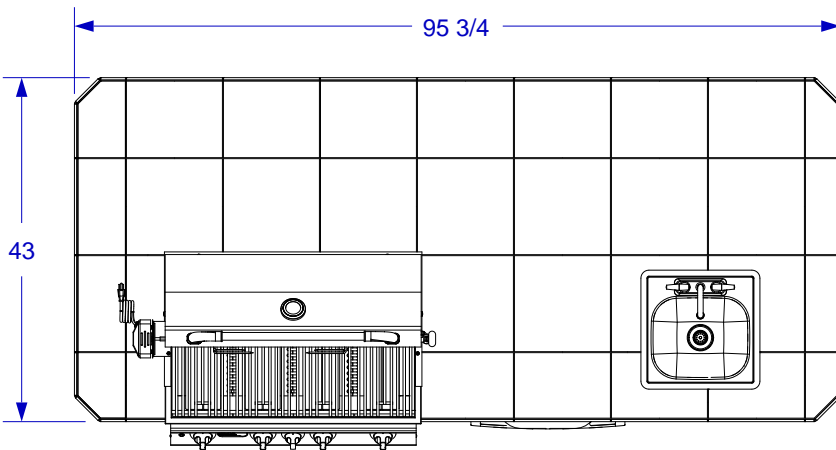

ISOMETRIC VIEW



TOP VIEW

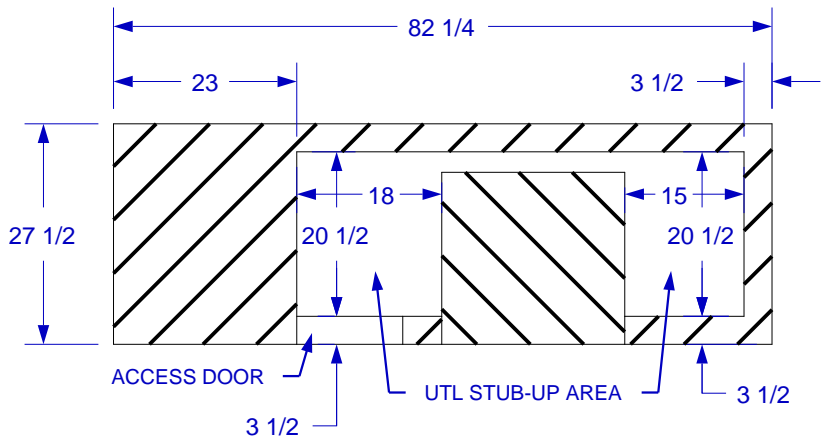

STUB-UP DIAGRAM  
 (SEE NOTE #2)

- NOTES:**
1. FOR ROCK FINISHES, ADD 1 1/2" ON ALL BASE SIDES.
  2. 6" MAX HEIGHT ON ALL STUB-UPS.
  3. SHOWN WITH STANDARD 4-BURNER ANGUS GRILL
  4. SCALE: 1/2" = 1'-0"
  5. REVISION: 01/2015